

# Combination Drench Shower/Eye Wash Unit

Model S19-310 (Shown)

Model S19-310F

Model S19-310FSS

Model S19-310SB

- Complies with American National Standard Z358.1-2004
- Galvanized Steel Protected with BRADTECT™ Safety Yellow Coating or All Stainless Steel
- Universal Identification Sign and Inspection Tag Included
- Full, One-Year Warranty

## Specifications

Combination Drench Shower/Eye Wash Unit saves space and fits easily into any work environment. Shower valve operates quickly by a pull rod with a triangular handle. Eye wash operated by a large, highly visible push handle. Safe, steady water flow under varying water supply conditions from 30-90 PSI is assured by integral flow control in the sprayhead assembly.

## Construction

Impact-resistant plastic shower head and bowl are colored bright yellow for high visibility in emergency situations or corrosion resistant stainless steel. Shower pull rod is stainless steel. Galvanized steel piping is additionally protected with BRADTECT™ safety yellow coating. S19-310FSS is all stainless steel construction.

## Standard Equipment

### Shower Head

10" (254mm) diameter yellow impact-resistant plastic or stainless steel.

### Shower Valve

Chrome-plated brass 1" IPS stay-open ball valve. Operated by stainless steel pull rod with triangular handle. S19-310FSS is all stainless steel.

### Eye Wash Bowl

10" (254mm) diameter yellow impact-resistant plastic or stainless steel.

### Standard Sprayhead Assembly

Chrome-plated brass sprayhead assembly with twin, soft flow, eye wash heads and protective sprayhead covers. The integral flow control assures safe, steady flow under varying water supply conditions from 30-90 PSI. S19-310FSS is all stainless steel.

### Eye Wash Valve

Chrome-plated 1/2" IPS stay-open ball valve. Hand operated by a large, highly visible safety yellow PVC push handle. S19-310FSS is all stainless steel.

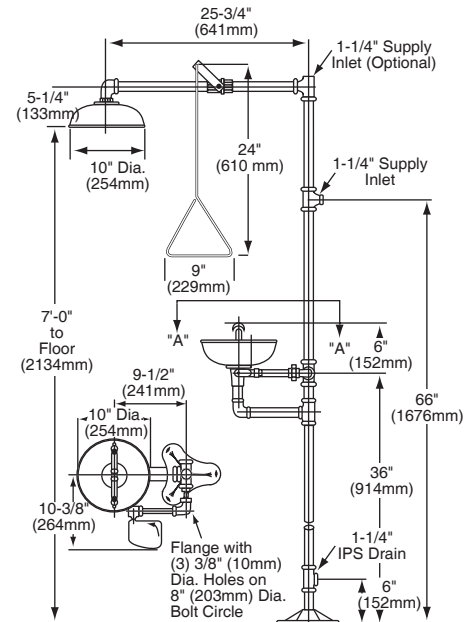

## Pipe and Fittings

1-1/4" galvanized steel protected with BRADTECT™ safety yellow coating. S19-310FSS is all stainless steel.

## Water Supply

1-1/4" IPS.

MODEL	
Model No.	Description
<input type="checkbox"/> S19-310	Combination Drench Shower/Eye Wash Unit-Plastic Shower Head and Bowl
<input type="checkbox"/> S19-310F	Combination Drench Shower/Eye Wash Unit-Stainless Steel Shower Head and Bowl
<input type="checkbox"/> S19-310FSS	Combination Drench Shower/Eye Wash Unit-All Stainless Steel
<input type="checkbox"/> S19-310SB	Combination Drench Shower/Eye Wash Unit -Plastic Shower Head and Stainless Steel Bowl

Document No. 4490

This information is subject to change without formal notice.  
© 2004 Bradley Corporation  
9-29-2004 (1 Page Total)

**Bradley**

P.O. Box 309, Menomonee Falls, WI 53052-0309  
Phone 1-800-BRADLEY FAX 262-251-5817  
Web Site: <http://www.bradleycorp.com>