

# CHICAGO FAUCETS



2100 SOUTH CLEARWATER DRIVE  
DES PLAINES, ILLINOIS 60018-5999

FITTING NO.

445-L9

SUBMITTED MODEL NO.

Last As Long As The Building

JOB NAME

ITEM NO.

SUBMITTED AS SHOWN

SUBMITTED AS NOTED

SEE ATTACHED FOR  
SUBMITTED MODIFICATION



ADA COMPLIANT

IS ASSUMED FOR USE OF SUPERCEDED OR VOIDED DATA.

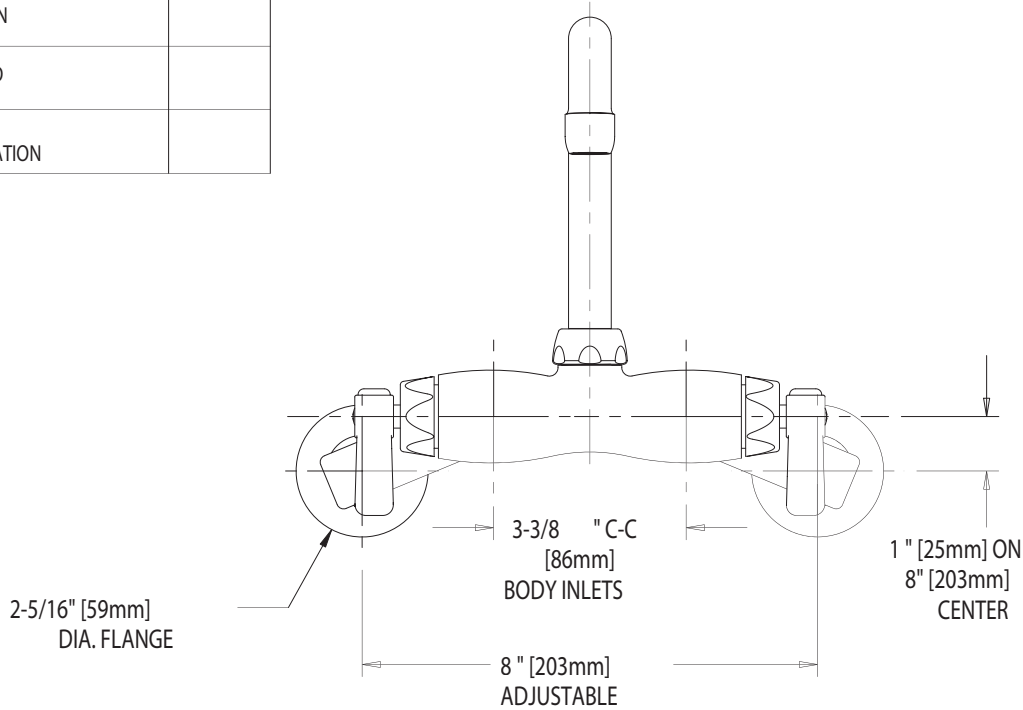

FRONT VIEW

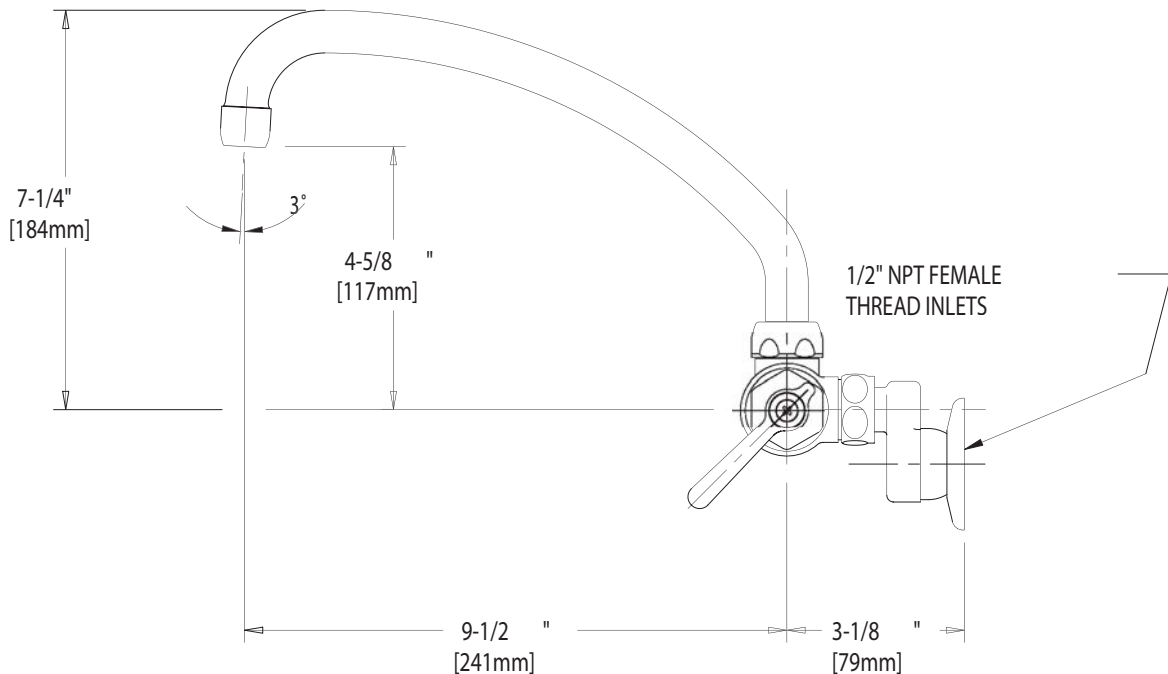

SIDE VIEW

DIMENSIONS IN INCHES AND [MILLIMETERS].

TECHNICAL DATA

- WALL MOUNTED FITTING
- L9 SWING SPOUT
- 369 INDEXED LEVER HANDLES
- QUATURN OPERATING CARTRIDGES
- "H" ADJUSTABLE SUPPLY ARMS
- FINISH: CHROME PLATE

- E3 SOFTFLO AERATOR
- 2.2 GPM [8.3 L/min.] FLOW RATE
- ASME A112.18.1M COMPLIANT
- CSA B125 COMPLIANT
- NSF 61 COMPLIANT

DATE: 04-23-02

BY: SID

CHK'D:

APP'D:

REV: A

445-L9

ROUGHING IN DIMENSIONS MAY VARY AND ARE SUBJECT TO CHANGE. NO RESPONSIBILITY