

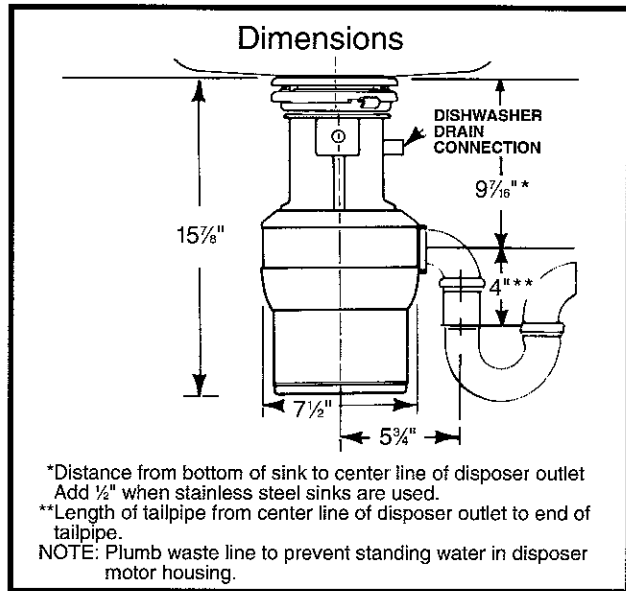

# PRO 17 3/4 HP Stainless Steel Garbage Disposer

## Submittal Sheet

- 7 full year parts and in-home service warranty\*
- 3/4 horsepower split phase motor
- Stainless steel grind chamber
- Exclusive polypropylene corrosion shield
- Automatic reversing action
- Quick-Lock mounting
- Easy twist fingertip control cover
- Permanently lubricated upper and lower bearings
- Stainless steel rotating shredder with two stainless steel 360° swivel impellers
- Dishwasher drain connection
- Overload protector manually reset
- Water seal
- Diamond ni-hard shredder ring
- Exclusive self-service "wrenchette"

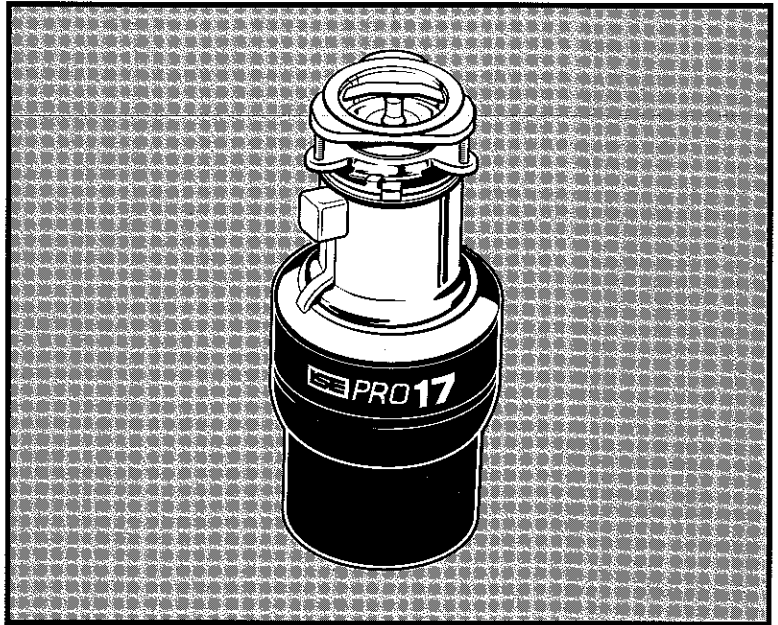

## Specifications

Type of Feed	Batch Feed	Overall Height	16"
On/Off Control	Lock Cover	Grind Chamber Cap.	7-1/2 cups
Motor	Split Phase	Motor Protection	Manual reset Overload
HP	3/4	Average Water Usage	1-1/2 Gallons Per Person Per Day
Volts	115	Average Electrical Usage	1/2 KWH Per Month
HZ	60	Drain Connection	1-1/2" Cushioned Slip Joint
RPM	1725	Dishwasher Drain Connection	Yes
Amp. (Avg. Load)	7.6		
Time Ratings	—		
Lubrication	Permanently Lubricated Upper & Lower Bearings		
Shipping Weight (Approx.)	24 lbs.		
Unit Finish	Acrylic Black Enamel Stainless Steel		

## Sample Specifications

Garbage Disposer(s) shall be In-Sink-Erator stainless steel Model PRO 17. Lock cover/batch feed, automatic reversing switch, with 3/4 H.P. split phase motor, corrosion protection shield, self-service wrenchette. Warranty - 7 full year parts and in-home service.

The complete ISE warranty and all parts covered is included in the Care & Use Booklet packed with each unit

Meets MIL-G-15840-B Type II

## Job Specifications