

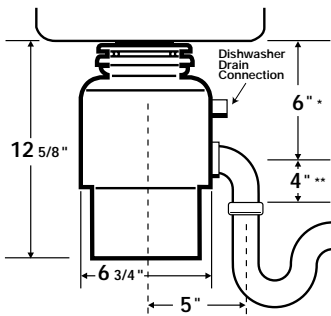

### Dimensions



\* Distance from bottom of sink to center line of disposer outlet.

Add 1/2" when stainless steel sinks are used.

\*\* Length of tailpipe from center line of disposer outlet to end of tailpipe.

NOTE: Plumb waste line to prevent standing water in disposer motor housing.



## Submittal Sheet

- 2 year parts and in-home service warranty\*
- plastic grind chamber
- Galvanized steel grinding elements with two stainless steel 360° swivel lugs
- Stainless steel sink flange with positive seal 1-piece plastic stopper
- Overload protector manual reset
- Permanently lubricated upper and lower bearings
- Quick Lock™ mounting for fast, easy installation
- Exclusive cushioned anti-splash baffle
- Dishwasher drain connection
- Exclusive self-service wrench

## Sample Specification

Food Waste Disposer(s) shall be In-Sink-Erator Badger 5, continuous feed, with 1/2 H.P. motor, galvanized steel grinding elements with two stainless steel 360° swivel lugs. Self-service wrench. Warranty - 2 year parts and in-home service.

\* The complete In-Sink-Erator warranty is included in the Care & Use Booklet, packed with each unit.

## Specifications

Type of Feed	Continuous
On/Off Control	Wall Switch
Motor	Single Phase
HP	1/2
Volts	120
HZ	60
RPM	1725
Amp. (Avg. Load)	6.9
Time Rating	Intermittent
Lubrication	Permanently Lubricated Upper & Lower Bearings
Shipping Weight (Approx.)	14 lbs. 11 oz.
Unit Finish	Waterborne Grey Enamel
Overall Height	12-5/8"
Grind Chamber Capacity	26 oz.
Motor Protection	Manual reset Overload
Average Water Usage	1/4 Gallon Per Person Per Day
Average Electrical Usage	1/2 KWH Per Month
Drain Connection	1-1/2" Cushioned Slip Joint
Dishwasher Drain Connection	Yes

## Job Specifications