

Just STYLIST GROUP

DL - SERIES - B - 20 GA.

SPACE SAVER - LEDGE TYPE DOUBLE BOWL

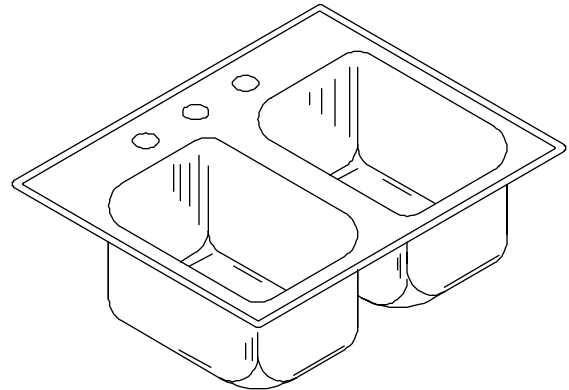

SUBMITTAL DATA

SPECIFICATION

Seamless die-drawn construction of type 304, 18-8 stainless steel. Interior and top surfaces polished to a non-porous Hand-Blended Just Finish with highlighted bowl rim. Fully coated underside insulates for sound, and reduces condensation. Straight-sided compartment with 1 3/4" radius corners provides greater capacity. Self-rimming top mount Grip-Rim Plus with 300 series stainless steel mounting channels. Conforms to ASME/ANSI A112.19.3M. Drain punch #35 centered for Just J-35 unless otherwise specified.

To be specified :

■ Faucet hole punching:

- (1) Hole Centered
- (2) Holes on 4" centers
- (3) Holes on 4" centers (illustrated)
- (4) Holes on 4" centers

Alternate Punching:

Faucet Model: _____

Punching required: _____

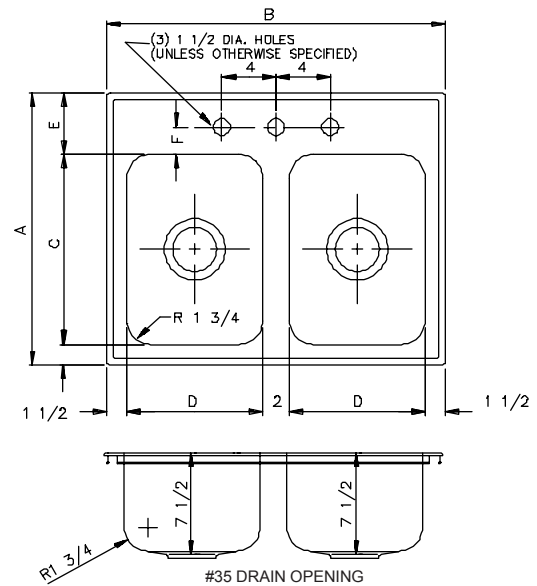

MODEL NO.	A	B	C	D	E	F	CUTOUT*
DL-1625-B-GR	16	25	10	10	4 1/2	2	15 1/4 x 24 1/4
DL-17537-B-GR	17 1/2	37	11 1/2	16	4 1/2	2	16 3/4 x 36 1/4
DL-1829-B-GR	18	29	12	12	4 1/2	2	17 1/4 x 28 1/4
DL-1925-B-GR	19	25	14	10	3 1/2	1 3/4	18 1/4 x 24 1/4
DL-1933-B-GR**	19	33	14	14	3 1/2	1 3/4	18 1/4 x 32 1/4
DL-2025-B-GR	20	25	14	10	4 1/2	2	19 1/4 x 24 1/4
DL-2037-B-GR	20	37	14	16	4 1/2	2	19 1/4 x 36 1/4
DL-2128-B-GR	21	28	16	11 1/2	3 1/2	1 3/4	20 1/4 x 27 1/4
DL-2228-B-GR	22	28	16	11 1/2	4 1/2	2	21 1/4 x 27 1/4

* Cutout dimensions shown (Front-to-Back) x (Left-to-Right) - Corners of cutout may be square or up to 1/2" radius.

** This model has 1 1/8 center partition and 1 15/16 end flanges.

FUNCTIONAL DESIGN, QUALITY, AND SPECIFICATIONS LISTED DESCRIBE THE JUST STANDARD OF QUALITY. WHEN MAKING COMPARISONS TO OTHER OFFERINGS, INSIST ON THE JUST QUALITY OF CONSTRUCTION.

Job Name _____	
Customer _____	
Architect/Engineer _____	
APPROVED FOR MANUFACTURING	
MODEL NO. _____	QTY. _____
COMPANY _____	
TITLE _____	DATE _____
SIGNATURE _____	

Just

MANUFACTURING COMPANY
 9233 KING STREET, FRANKLIN PARK, ILLINOIS 60131
 PHONE: (847) 678-5150 FAX: (847) 678-6817