

NEW! 370-SERIES Access Riser



Riser allows burial of a 370 System up to a maximum depth of 18" below grade.

A convenient chamber for all your pump's electrical and piping connections – out of sight and below grade. Riser simply slides over the sealed 370 system. Cover is retained by 4 stainless steel bolts and features a twist-lock design with provision for padlock to deter unwanted entry.

Specifications:

Weight: 28 lbs.- (Riser and Cover)
Riser Height: 18-3/4"
Total Height with Cover: 20-1/2"
Diameter: 32"

Access Riser Installation Kits

Liberty's installation kits provide all the components for a professional installation inside the riser. Kit includes: JB-Series wiring box and hardware, check valve with a disconnect union feature, coupling and elbows (PVC piping not included). Kits available in 2" discharge and vent size only.

TOP VIEW



MODEL	DESCRIPTION
AR18	Access Riser
AC18	Access Riser Cover (Environmental Green)
ARC18	Kit, Access Riser with Cover
ARCKIT115	Kit, Access Riser with Cover and 2" installation accessories - 115V
ARCKIT230	Kit, Access Riser with Cover and 2" installation accessories - 230V
IKIT2-115	Installation Kit 2", 115V
IKIT2-230	Installation Kit 2", 230V

Specifications subject to change without notice.

Liberty Pumps™

370-SERIES

Pre-Assembled Sewage System



Fully Alarmed Systems

**NEW!
 XL Series,
 10' Stack Test
 Models IAPMO
 Listed Basin**

**NEW!
 Access Riser
 for below-grade
 piping installations**



**Better Quality. Added Features.
 Superior Performance**

370-SERIES Standard Systems



FEATURES

- Larger basin – 40% more capacity than standard 18" X 30" basins – decreases switch cycles, improves pump life
- Integrally molded torque stops secure the pump in its proper position
- Integrally molded anti-flotation collar
- Integrally molded inlet sized to accept a 4" flexible coupling
- Integrally molded handles to ease transportation and installation
- Durable polyethylene construction with radial ribs for added strength
- Completely assembled at the factory with a schedule 80 PVC discharge pipe
- Available with any of Liberty's 2" solids-handling sewage pumps
- Durable, corrosion proof structural foam cover (Steel and split cover options available)



SPECIFICATIONS: 2" DISCHARGE SYSTEMS

MODEL	HP	VOLTS	PHASE	DISCHARGE	WGT. LBS.
372/LE41A	4/10	115	1	2"	60
372/LE51A	1/2	115	1	2"	64
372/LE52A	1/2	208-230	1	2"	63
372/LE71A	3/4	115	1	2"	83
372/LE72A	3/4	208-230	1	2"	83
372/LE102A*	1	208-230	1	2"	86
372/LEH102A*	1	208-230	1	2"	86

For 3" discharge systems change model number from "372" to "373."
EXAMPLE: 373/LE41A

See specific LE-Series literature for complete pump performance and specifications.
* High head applications only. Consult factory for proper pump sizing.

TANK DIMENSIONS

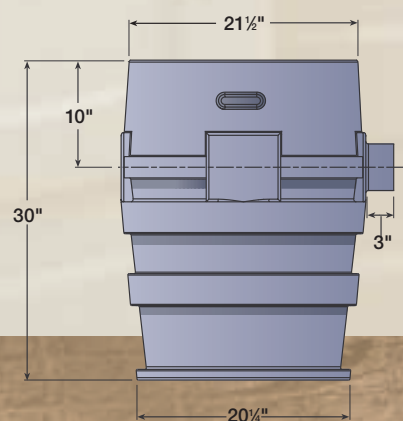

370-SERIES Alarmed Systems

Now, have the assurance of early warning in the event of a high-level condition with an alarm option installed from the factory! We do the work for you by mounting the alarm float in the basin at its proper level – no need to even open the cover! Simply mount the alarm panel in its desired location, supply power and connect the alarm float leads! Offered with three different alarm options for indoor or outdoor applications.



ALM-2

Indoor 115V Alarm with 9 volt Battery Back-up



ALM-2W

Outdoor Rated 115 volt Alarm



ALM-3W

Outdoor NEMA 4X Commercial Alarm



HOW TO ORDER:

Alarm Model	Add Suffix	Ordering Example
ALM-2	/A2	372/LE41A/A2
ALM-2W	/A2W	372/LE41A/A2W
ALM-3W	/A3W	372/LE41A/A3W

Alarm float is pre-set at proper level in basin.
Alarm panel packaged with unit.

NEW! 370XL-SERIES IAPMO Listed Basin 10' STACK TEST MODEL



Liberty's 370XL-Series features a IAPMO listed basin.

The system is specially designed to pass a 10' stack test required by code in some markets.

The 370XL-Series has all the same features as the standard 370 except for heavy gauge steel cover, 16 stainless steel cover bolts and heavy-duty cover gasket.

To order, simply add "XL" to any standard 370 Series System.

Example: 372XL/LE41A

