

# ULTRA-SENSE<sup>®</sup>

## Sensor Activated Lavatory Faucet

- S-6110-G: With grid strainer drain assembly
- S-6110: Faucet only

**Ultra-Sense** transformer-powered, sensor-activated lavatory faucet to meter a single tempered or cold water supply. Infrared reflective intensity detection system. 4" center deck plate, 1.5 gpm low profile. Vandal-resistant aerator. 10-second factory set cycle time. In-line strainer. **(Transformer must be specified separately.)**

**Modifications:**

**Add:**

- Suffix **FR:** 0.5 gpm flow restrictor
- Suffix **OFG:** Offset grid strainer drain assembly in place of standard grid drain
- Suffix **SM:** Single hole mounting

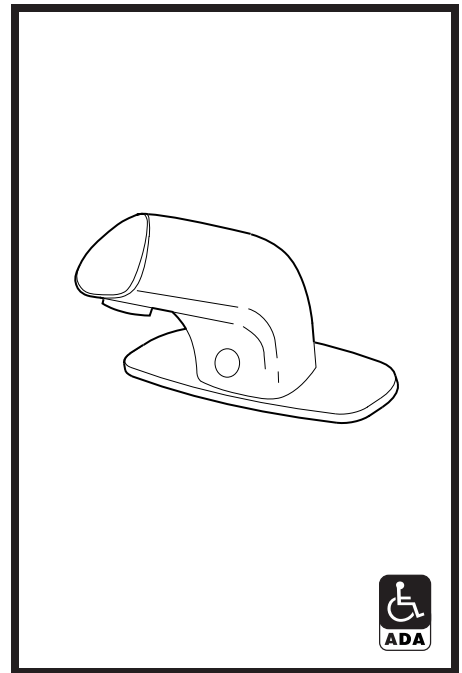

**SYMMONS PRODUCTS MEET  
ANSI A112.18.1M, EPA '92  
AND ALL KNOWN FLOW RATE  
REQUIREMENTS.  
Metering Faucets  
0.25 gallons per cycle (1.0 L/cycle)**

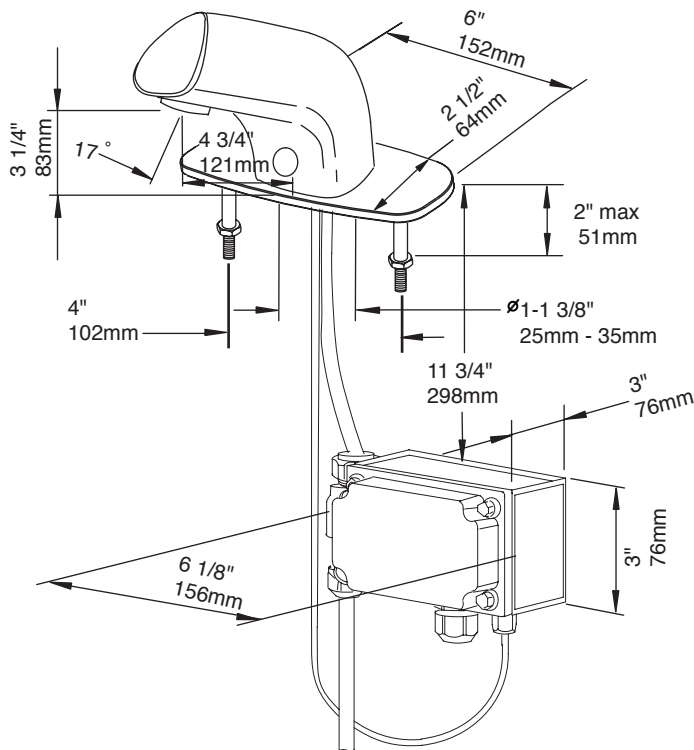

**Job/Location**

.....  
 .....

**Engineer**

.....  
 .....

**Contractor**

.....  
 .....

For ADA compliance (Americans with Disabilities Act) consult ADAAG or your state regulations for proper product choice and mounting locations.

